

REVISIONS				
REV	ECN #	DESCRIPTION	REV. BY/DATE	APR. BY
A	-----	INITIAL RELEASE	04/2000	

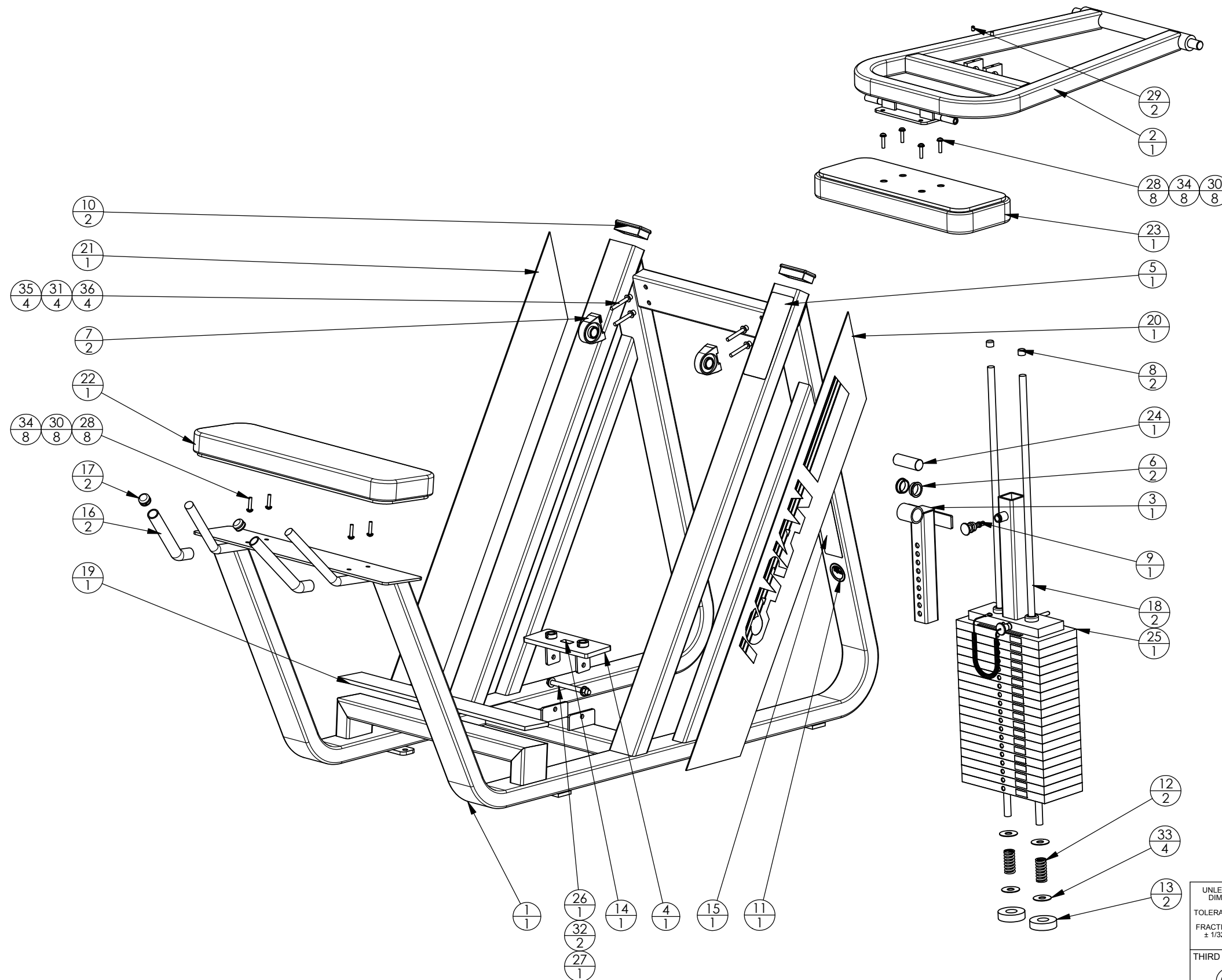

ITEM NO.	QTY.	PART NO.	DESCRIPTION
1	1	615-SA-1	615 MAIN FRAME ASSY.
2	1	615-SA-2	615 SUPPORT ARM ASSY.
3	1	615-SA-3	615 CHROME ADJ. ASSY
4	1	615-SA-5	615 BOTTOM PLATE, WEIGHT STACK, PIVOT
5	1	AC0615B	LABEL, INSTRUCTION, "DONKEY CALF 615"
6	2	AC1022	BUSHING, BRONZE, 1.265" ID x 1 1/2" OD
7	2	AC1026	PILLOW BLOCK BEARING 2 BOLT, TAPPED
8	2	AC1040	CAP, GUIDE ROD, DIA. 3/4
9	1	AC1051-MS	SNAP PIN, SMALL M-PULL
10	2	AC1057	CAP, BLACK PLASTIC, 2 x 4
11	1	AC1161	LABEL, ROUND, "MADE IN USA"
12	2	AC1062	SPRING, COMPRESSION, 1 3/32 OD x 29/32 ID x (2 1/2)
13	2	AC1148	WEIGHT STACK BUMPER
14	1	AC1164	LABEL, F.P.I. SERIAL NUMBER
15	1	AC1183	LABEL, "WARNING, SERIOUS INJURY..."
16	2	AC1226-12	RUBBERGRIP, DIA 1 x (10 1/4)
17	2	AC218	HANDLE END CAP W/SET SCREWS, DIA 1"
18	2	CH1214	STEEL BAR RND, DIA. 3/4" x (52 5/8), #5
19	1	CP1023	CUT PIECE, CREPE, 7/16 x 3 3/4 x 29 1/2
20	1	CP1091	ABS BLACK, 1/8 x 7 1/2 x 54 1/2, LEFT WITH LOGO
21	1	CP1092	ABS BLACK, 1/8 x 7 1/2 x 54 1/2, RIGHT, WITH LOGO
22	1	PD1103	PAD, 9 x 31, 4 HOLES
23	1	PD1104	PAD, 9 x 24, 4 HOLES
24	1	PF1370	STEEL BAR RND DIA 1.245 x (3 1/2)
25	1	WS4001	WEIGHT STACK, 20 PLATE, 400 LBS.
26	1	FA1022	BOLT, HEX HEAD, ZINC, 1/2-13 x 6
27	1	FA1040	NUT, HEX, 1/2-13
28	8	FA1072	BOLT, BUTTON HEAD, 5/16-18 x 1 1/2
29	2	FA1086	SCREW, SET, SCKT, CUP POINT, 5/16-18 x 1/2
30	8	FA1106	WASHER, FLAT, 5/16 ID x 11/16 OD
31	4	FA1107	WASHER, FLAT, 3/8 ID x 13/16 OD
32	2	FA1109	WASHER, FLAT, 1/2 ID x 1 1/16 OD
33	4	FA1111	WASHER, FENDER, 3/4 ID x 2 OD
34	8	FA1116	WASHER, SPLIT, 5/16 ID
35	4	FA1117	WASHER, SPLIT, 3/8 ID
36	4	FA1143	BOLT, SOCKET HEAD, 3/8-16 x 2 3/4

WEIGHT: 740 LBS.

UNLESS OTHERWISE SPECIFIED DIMENSIONS ARE IN INCHES

TOLERANCES ARE:
 FRACTIONS ± 1/32 DECIMALS .XX ± .01 ANGLES ± 1°
 .XXX ± .005

THIRD ANGLE PROJECTION



DO NOT SCALE DRAWING



FITNESS PRODUCTS INTERNATIONAL
 ICARIAN FLITE ABENCH JADE STRETCH CENTER
 12660 BRANFORD ST. SUN VALLEY, CA. 91352

APPROVALS	DATE
DESIGNED BY KLS	05/91
MODELED BY JCV	11/99
DRAWN BY RJB	04/00
APPROVED BY	

TITLE	SCALE
DONKEY CALF	1:12
SIZE	SHEET
B	1 OF 1
DWG. NO.	REV
615-EXP	A

615 Donkey Calf

Part Number	Description	Bubble Number
CW615SA1-211	ASSY,FRAME,MAIN,615,SKY WHITE	1.01
CW615SA1-221	ASSY,FRAME,MAIN,615,BLACK	1.02
CW615SA1-231	ASSY,FRAME,MAIN,615,RED	1.03
CW615SA1-241	ASSY,FRAME,MAIN,615,PLAT SPRKLE	1.04
CW615SA1-251	ASSY,FRAME,MAIN,615,SILVER	1.05
CW615SA1-261	ASSY,FRAME,MAIN,615,BLUE	1.06
CW615SA1-271	ASSY,FRAME,MAIN,615,CHARCOAL	1.07
CW615SA1-281	ASSY,FRAME,MAIN,615,CATH GRAY	1.08
CW615SA1-291	ASSY,FRAME,MAIN,615,SILVER VIEN	1.09
CW615SA1-311	ASSY,FRAME,MAIN,615,STONE HG	1.11
CW615SA1-321	ASSY,FRAME,MAIN,615,TITANIUM HG	1.12
CW615SA1-331	ASSY,FRAME,MAIN,615,WHITE GLOSS	1.13
CW615SA1-341	ASSY,FRAME,MAIN,615,BLACK ONYX	1.14
CW615SA1-351	ASSY,FRAME,MAIN,615,LT. BRONZE	1.15
CW615SA1-361	ASSY,FRAME,MAIN,615,SAPPHIRE BL	1.16
CW615SA2-211	ASSY,ARM,SUPPORT,615,SKY WHITE	2.01
CW615SA2-221	ASSY,ARM,SUPPORT,615,BLACK	2.02
CW615SA2-231	ASSY,ARM,SUPPORT,615,RED	2.03
CW615SA2-241	ASSY,ARM,SUPPORT,615,PLAT SPKLE	2.04
CW615SA2-251	ASSY,ARM,SUPPORT,615,SILVER	2.05
CW615SA2-261	ASSY,ARM,SUPPORT,615,BLUE	2.06
CW615SA2-271	ASSY,ARM,SUPPORT,615,CHARCOAL	2.07
CW615SA2-281	ASSY,ARM,SUPPORT,615,CATH GRY	2.08
CW615SA2-291	ASSY,ARM,SUPPORT,615,SILVER VIEN	2.09
CW615SA2-311	ASSY,ARM,SUPPORT,615,STONE HG	2.11
CW615SA2-321	ASSY,ARM,SUPPORT,615,TITANIUM HG	2.12
CW615SA2-331	ASSY,ARM,SUPPORT,615,WHITE GLOSS	2.13
CW615SA2-341	ASSY,ARM,SUPPORT,615,BLACK ONYX	2.14
CW615SA2-351	ASSY,ARM,SUPPORT,615,LIGHT BRONZE	2.15
CW615SA2-361	ASSY,ARM,SUPPORT,615,SAPPHIRE BLUE	2.16
CW615SA3-711	ASSY,ADJUST,615,CHROME	3
CW615SA5-211	ASSY,BOTTOM PLATE,WEIGHT STACK,PIVO	4.01
CW615SA5-221	ASSY,BOTTOM PLATE,WEIGHT STACK,PIVO	4.02
CW615SA5-231	ASSY,BOTTOM PLATE,WEIGHT STACK,PIVO	4.03
CW615SA5-241	ASSY,BOTTOM PLATE,WEIGHT STACK,PIVO	4.04
CW615SA5-251	ASSY,BOTTOM PLATE,WEIGHT STACK,PIVO	4.05
CW615SA5-261	ASSY,BOTTOM PLATE,WEIGHT STACK,PIVO	4.06
CW615SA5-271	ASSY,BOTTOM PLATE,WEIGHT STACK,PIVO	4.07
CW615SA5-281	ASSY,BOTTOM PLATE,WEIGHT STACK,PIVO	4.08
CW615SA5-291	ASSY,BOTTOM PLATE,WEIGHT STACK,PIVO	4.09
CW615SA5-311	ASSY,BOTTOM PLATE,WEIGHT STACK,PIVO	4.11
CW615SA5-321	ASSY,BOTTOM PLATE,WEIGHT STACK,PIVO	4.12
CW615SA5-331	ASSY,BOTTOM PLATE,WEIGHT STACK,PIVO	4.13
CW615SA5-341	ASSY,BOTTOM PLATE,WEIGHT STACK,PIVO	4.14
CW615SA5-351	ASSY,BOTTOM PLATE,WEIGHT STACK,PIVO	4.15
CW615SA5-361	ASSY,BOTTOM PLATE,WEIGHT STACK,PIVO	4.16
CW10043-135	BUSHING, BRONZE, 1 1/4" ID X 1 1/2"	6
CW615SA4-721	ASSY,TOP WEIGHT,W/TUBE RECEIVER,615	6
CW12406-101	PILLOW BLOCK, BEARING, 2 BOLT	7

CW12404-101	CAP, GUIDE ROD,DIA 3/4, BLK	8
CW30165-751	ASSY, POP PIN, 0.450 DIA HANDLE, B	9
CW11311-102	ENDCAP, REC TUBE, 2X4, BLK PLASTIC	10
CWAC1062-901	SPRING, COMPRESSION, 1 3/32 OD X 29	12
CW12402-101	BUMPER, WEIGHT STACK, BLK RUBBER	13
CWGR2610-250	GRIP,RUBBER, 1" DIA, 10-1/4"	16
CWAC218-901	HANDLE END CAP W/SET SCREWS, DIA 1"	17
CWPF1214-711	GUIDE ROD,STEEL,OD 3/4 X 52 5/8, CH	18
CW30014-119	CUT PIECE, CREPE, 7/16 X 3 3/4 X 29	19
CW30510-101	CUT PIECE, ABS BLACK, 1/8 X 7 1/2 X	20
CW30511-101	CUT PIECE, ABS BLACK, 1/8 X 7 1/2 X	21
CWPD1103A-101	PAD,FLAT,9X31,4HOLES,BLACK	22.01
CWPD1103A-102	PAD,FLAT,9X31,4HOLES,RYL BL	22.02
CWPD1103A-103	PAD,FLAT,9X31,4HOLES,DVE GRY	22.03
CWPD1103A-104	PAD,FLAT,9X31,4HOLES,CROCUS	22.04
CWPD1103A-105	PAD,FLAT,9X31,4HOLES,GROTTO	22.05
CWPD1103A-106	PAD,FLAT,9X31,4HOLES,GRAPHITE	22.06
CWPD1103A-107	PAD,FLAT,9X31,4HOLES,RED	22.07
CWPD1103A-109	PAD,FLAT,9X31,4HOLES,TURQSE	22.09
CWPD1103A-110	PAD,FLAT,9X31,4HOLES,RASP	22.1
CWPD1103A-111	PAD,FLAT,9X31,4HOLES,PLUM	22.11
CWPD1103A-112	PAD,FLAT,9X31,4HOLES,REGIMENT	22.12
CWPD1103A-113	PAD,FLAT,9X31,4HOLES,SPC BLUE	22.13
CWPD1103A-115	PAD,FLAT,9X31,4HOLES,BLK LTHR	22.15
CWPD1103A-116	PAD,FLAT,9X31,4HOLES,NVBL LTH	22.16
CWPD1103A-117	PAD,FLAT,9X31,4HOLES,PUTTY	22.17
CWPD1103A-118	PAD,FLAT,9X31,4HOLES,IMPRL BL	22.18
CWPD1103A-119	PAD,FLAT,9X31,4HOLES,YEW GREEN	22.19
CWPD1103A-120	PAD,FLAT,9X31,4HOLES,DSTY JADE	22.2
CWPD1103A-121	PAD,FLAT,9X31,4HLS,TRRA CTTA	22.21
CWPD1103A-123	PAD,FLAT,9X31,4HLS,ASH LTHR	22.23
CWPD1103A-124	PAD,FLAT,9X31,4HL,CERULEAN LTH	22.24
CWPD1103A-125	PAD,FLAT,9X31,4HL,CHARCOAL LTH	22.25
CWPD1103A-126	PAD,FLAT,9X31,4HLS,HUNTER LTHR	22.26
CWPD1103A-127	PAD,FLAT,9X31,4HLS,MOSS LTHR	22.27
CWPD1103A-128	PAD,FLAT,9X31,4HLS,SPICE LTHR	22.28
CWPD1103A-129	PAD,FLAT,9X31,4HLS,TOMATO LTHR	22.29
CWPD1104B-102	PAD,9X24,4HOLES,W/BP,RYL BL	23.02
CWPD1104B-103	PAD,9X24,4HOLES,W/BP,DVE GRY	23.03
CWPD1104B-104	PAD,9X24,4HOLES,W/BP,CROCUS	23.04
CWPD1104B-105	PAD,9X24,4HOLES,W/BP,GROTTO	23.05
CWPD1104B-106	PAD,9X24,4HOLES,W/BP,GRAPHITE	23.06
CWPD1104B-107	PAD,9X24,4HOLES,W/BP,RED	23.07
CWPD1104B-109	PAD,9X24,4HOLES,W/BP,TURQSE	23.09
CWPD1104B-110	PAD,9X24,4HOLES,W/BP,RASP	23.1
CWPD1104B-111	PAD,9X24,4HOLES,W/BP,PLUM	23.11
CWPD1104B-112	PAD,9X24,4HOLES,W/BP,REGIMENT	23.12
CWPD1104B-113	PAD,9X24,4HOLES,W/BP,SPC BLUE	23.13
CWPD1104B-115	PAD,9X24,4HOLES,W/BP,BLK LTHR	23.15
CWPD1104B-116	PAD,9X24,4HOLES,W/BP,NVBL LTH	23.16
CWPD1104B-118	PAD,9X24,4HOLES,W/BP,IMPRL BLUE	23.18

CWPD1104B-119	PAD,9X24,4HOLES,W/BP,YEW GREEN	23.19
CWPD1104B-120	PAD,9X24,4HOLES,W/BP,DUSTY JADE	23.2
CWPD1104B-123	PAD,9X24,4HOLES,W/BP,ASH LTHR	23.23
CWPD1104B-124	PAD,9X24,4HOLES,W/BP,CERULEAN LTHR	23.24
CWPD1104B-125	PAD,9X24,4HOLES,W/BP,CHARCOAL LTHR	23.25
CWPD1104B-126	PAD,9X24,4HOLES,W/BP,HUNTER LTHR	23.26
CWPD1104B-127	PAD,9X24,4HOLES,W/BP,MOSS LTHR	23.27
CWPD1104B-128	PAD,9X24,4HOLES,W/BP,SPICE LTHR	23.28
CWPD1104B-129	PAD,9X24,4HOLES,W/BP,TOMATO LTHR	23.29
CWPF1370-731	BAR,STEEL, RND, DIA 1.245" X (3 1/2	24
CW30120-400	WEIGHT STACK,400 LBS,MTP-S,1011,111	25
CWHCCN050-600	SCREW, HEX HEAD, ZINC, 1/2-13 X 6	26
CWKMYN050-044	NUT, HEX, UNC, 1/2-13, BLK XY	27
CWTAYN031-150	SCREW, BUTTON HEAD, BLK XYLAN,5/16	28
CWEANN031-050	SCREW,SET,SCKT,CUP POINT,5/16-18 X	29
CWWBKN031-007	WASHER, FLAT, TYPE A, SAE, 5/16 ID	30
CWWBKN038-007	WASHER, FLAT, TYPE A, SAE, 3/8 ID	31
CWWBKN050-010	WASHER, FLAT, TYPE A, SAE, 1/2 ID X	32
CWWCKN075-015	WASHER, FLAT, TYPE A, WIDE, 3/4 ID	33
CWWALYN031-008	WASHER, SPLIT, 5/16 ID, BL	34
CWWALYN038-009	WASHER, SPLIT, 3/8 ID, BLK XYLAN	35
CWCAYN038-275	SCREW, SOCKET HEAD, BLK XYLAN, 3/	36
CW30010-101	LABEL,WARNING STRENGTH	37
CW30051-101	LABEL,INSTRUCTION,615	38
CW31759-101	LABEL,SMALL PRECOR USA ICARIAN LINE	39
CW10520-721	ASSY, PLATE, WEIGHT, 20 LBS, WRKL B	202
CWAC1133-101	BUSHING, WEIGHT PLATE, LDPE PLASTIC	203
CWLDNN038-200	PIN, ROLL, DIA 3/8 X 2	250
CW30184-901	ASSY,BARREL, TOP PLATE,ALUMINUM	251
CW30389-721	WELDMENT, WEIGHT, TOP, MTP-S, PF101	258
CW30389-901	WELDMENT, WEIGHT, TOP, MTP-S, PF101	258
CWAC1185-101	LABL,KEEP HND&FT CLR(CEMCO)3/8X6.75	259
CW30132-711	SELECTOR STEM, 20 PLATE,0 .875 DIA,	308
CW12401-114	LABEL, WEIGHT PLATE, 40 LBS/ 18.2 K	327
CW12401-120	LABEL, WEIGHT PLATE, 60 LBS/ 27.3 K	333
CW12401-124	LABEL, WEIGHT PLATE, 80 LBS/ 36.4 K	337
CW12401-128	LABEL, WEIGHT PLATE, 100 LBS/ 45.5	341
CW12401-130	LABEL, WEIGHT PLATE, 120 LBS/ 54.6	343
CW12401-132	LABEL, WEIGHT PLATE, 140 LBS/ 63.6	345
CW12401-134	LABEL, WEIGHT PLATE, 160 LBS/ 72.7	347
CW12401-136	LABEL, WEIGHT PLATE, 180 LBS/ 81.8	349
CW12401-138	LABEL, WEIGHT PLATE, 200 LBS/ 90.9	351
CW12401-140	LABEL, WEIGHT PLATE, 220 LBS/ 100 K	353
CW12401-142	LABEL, WEIGHT PLATE, 240 LBS/ 109.1	355
CW12401-144	LABEL, WEIGHT PLATE, 260 LBS/ 118.2	357
CW12401-145	LABEL, WEIGHT PLATE, 280 LBS/ 127.3	358
CW12401-146	LABEL, WEIGHT PLATE, 300 LBS/ 136.4	359
CW12401-147	LABEL, WEIGHT PLATE, 320 LBS/ 145.5	360
CW12401-148	LABEL, WEIGHT PLATE, 340 LBS/ 154.5	361
CW12401-149	LABEL, WEIGHT PLATE, 360 LBS/ 163.6	362
CW12401-150	LABEL, WEIGHT PLATE, 380 LBS/ 172.7	363

CW12401-151
CWAC1178-101

LABEL, WEIGHT PLATE, 400 LBS/ 181.8
FLOOR PROTECTOR, RUBBER, 2.563 X 6.

364
501